

# LEON CREEK WRC PRIMARY CLARIFIER Nos. 1 AND 2 REHABILITATION PROJECT

## Solicitation No. CO-00751-LE

Non-Mandatory Pre-Bid Meeting

April 15, 2024

Lindsay Esquivel

Contract Administrator

Marisol V. Robles

SBOP Manager

Eric Eckols, P.E.

Project Engineer

Javier Garcia, P.E.

Design Consultant

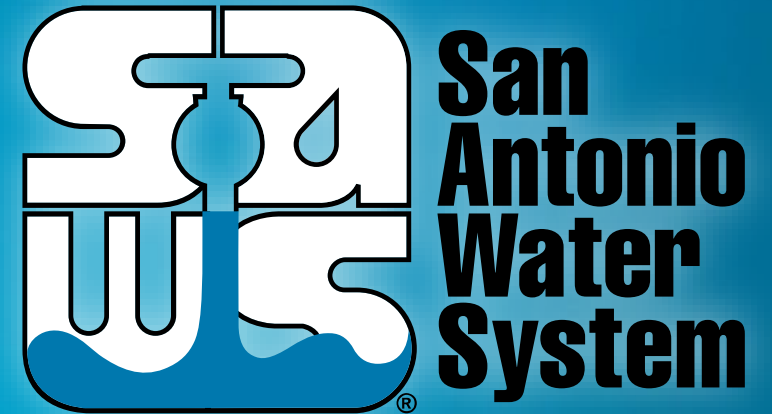

MAKING SAN ANTONIO  
**WATERFUL** 

# Oral Statements

Oral statements or discussion during the non-mandatory pre-bid meeting today will not be binding, nor will it change or affect the terms or conditions within the Plans and Specifications of this Project. Changes, if any, will be addressed in writing only via an Addendum.

# Agenda

- General Information
- SBOP Requirements
- Contract Solicitation Website
- Vendor Registration
- Contract Requirements
- Bid Packet Preparation
- Bid Opening Procedures
- Solicitation Schedule
- Restriction on Communication
- Project Location
- Project Overview
- Project Details
- Special Conditions
- Additive and Deductive Alternates
- Allowances
- Questions

# General Information

- This is a Non-Mandatory pre-bid site visit meeting
- This presentation and the attendance sheet will be posted on the SAWS website by the end of the business day
- Key project information:
  - Construction duration is 390 calendar days
  - Estimated budget is \$5,300,000.00
- Construction services being procured through low-bid

# Aspirational SBOP Goal

**19%**

**The aspirational SBOP goal is 19%  
of your total bid price.**

# Minimum Qualifications for SBOP recognition:

- South Central Texas Regional Certification Agency
  - Must be SBE-Certified (including MBEs and WBEs), or,
  - Texas Historically Underutilized Business “HUB” Program-certified
- Local Office or Local Equipment Yard
  - Bexar, Comal, Guadalupe, Hays, Kendall, Travis, and Williamson counties

# Good Faith Effort Plan (GFEP) FAQs

•**Q: Is the 19% SBOP goal mandatory?**

A: No, but we ask prime contractors to do their best with good faith outreach efforts. If the goal is not met, proof of outreach efforts is required with the submittal.

•**Q: What if I am having trouble finding SMWB-certified subcontractors?**

A: Outreach lists from the South Central Texas Regional Certification Agency are now Excel-exportable at [www.sctrca.sctrca.org](http://www.sctrca.sctrca.org). If you are having trouble with the downloads, please email the SBOP Manager.

•**Q: I'm a prime contractor. If my business is SMWB-certified, do I need to find SMWB subs?**

A: If your firm is SMWB-certified, you will most likely meet the goal. However, the GFEP is a required document, and a good faith outreach effort is still necessary.

•**Q: Do I need to include all of my subcontractors and suppliers in the GFEP or just those that qualify towards the SBOP goal?**

A: All subcontractors and suppliers need to be included in the GFEP, even those that may not count towards the SBOP goal.

•**Q: What if I have questions about the GFEP?**

A: Please contact the SBOP Manager at [Marisol.Robles@saws.org](mailto:Marisol.Robles@saws.org). GFEP questions can be asked at any time before the submittal is due.

# Post Award: Subcontractor Payment & Utilization Reporting (S.P.U.R.) System Use is contractually required.

## Functions:

1. Subcontractor & Supplier Payment Tracking
2. Subcontractor and Supplier Additions or Substitutions
3. Must be Current and Accurate before Retainage is released

<https://saws.smwbe.com>





# SBOP Questions

Questions related to SMWB-certified companies' participation or completion of the Good Faith Effort Plan (GFEP) may be directed to the SBOP Manager until the deadline.

Contact information:

**Marisol V. Robles**

SBOP Manager

Contracting Department

Email: [marisol.robles@saws.org](mailto:marisol.robles@saws.org)

# Contract Solicitations Website

- To locate the Contract Solicitations website, choose Resources

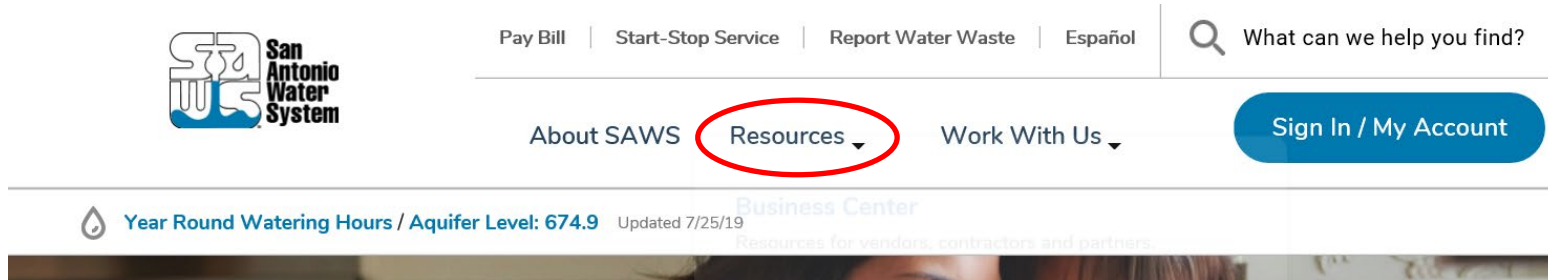

- Click on Business Center
- At the drop down menu choose Contract Solicitations

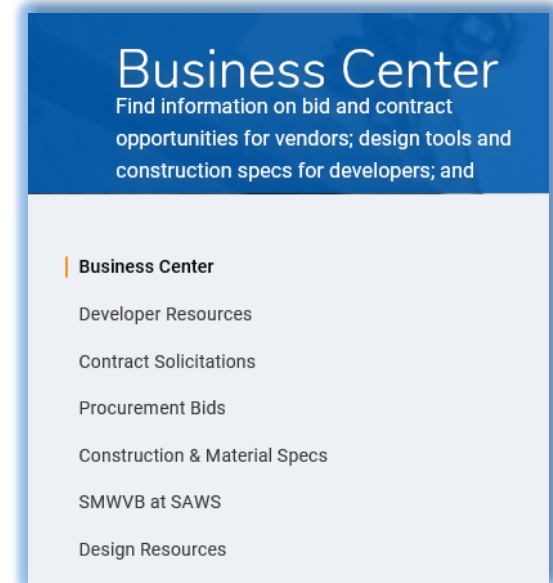

# Contract Solicitations Website

- Choose the specific project
- The following buttons are now located under the advertisement:
  - Notify Me
  - Plan Holder's List
  - Downloads
    - Plans
    - Specs
    - Addendums
    - Geotechnical Data Report

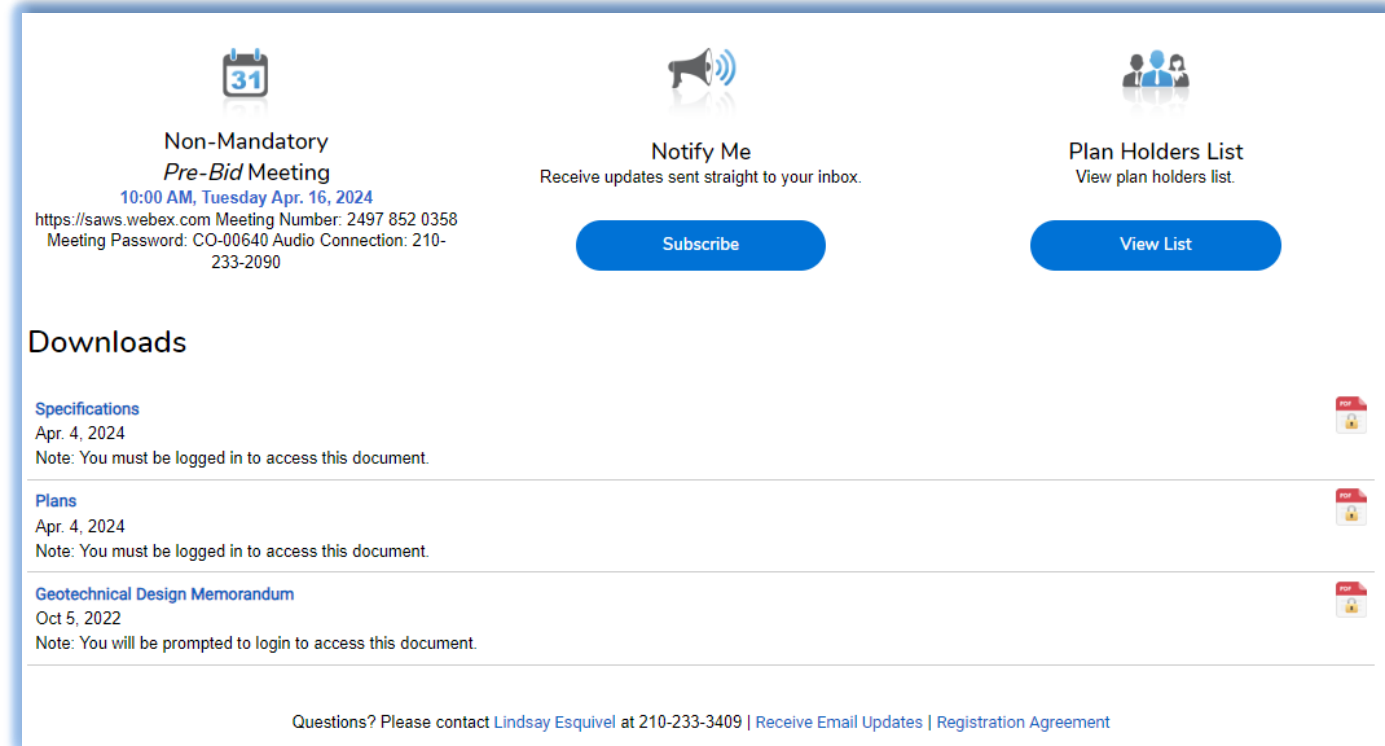

The screenshot displays the website interface for a contract solicitation. It features three main sections at the top: a calendar icon for a 'Non-Mandatory Pre-Bid Meeting' on Tuesday, April 16, 2024, at 10:00 AM, with a meeting link and password; a 'Notify Me' section with a megaphone icon and a 'Subscribe' button; and a 'Plan Holders List' section with a group icon and a 'View List' button. Below these is a 'Downloads' section containing three items: 'Specifications' (Apr. 4, 2024), 'Plans' (Apr. 4, 2024), and 'Geotechnical Design Memorandum' (Oct 5, 2022). Each download item includes a note about login requirements and a PDF icon. At the bottom, there is a footer with contact information for Lindsay Esquivel and links for email updates and registration agreement.

# Vendor Registration & Notification (VRN)

- Please register through SAWS Vendor Registration Program on the SAWS website at [www.saws.org](http://www.saws.org) to ensure access to the latest information.
- To receive updates on specific projects, registered vendors must 'Subscribe' to the project by selecting the project and clicking 'Subscribe' under the Notify Me box.

[https://apps.saws.org/Business\\_Center/Contractsol/](https://apps.saws.org/Business_Center/Contractsol/)

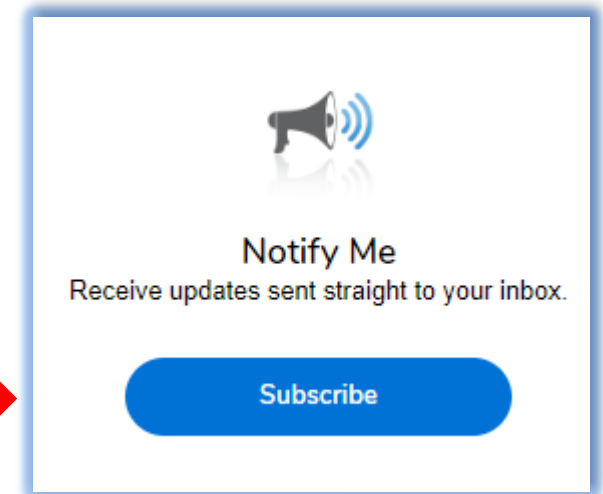

# Contract Requirements

## Prevailing Wage Rate and Labor Standards – Section 2.10 of the General Conditions

- Certified payroll to be submitted on weekly basis including weeks in which work is not performed by noting as such
- Wage decisions are included within the specifications **\*\* Original Specs & Addendum I**
- Contractors (and their subcontractors) shall utilize LCP Tracker
  - Site visits by SAWS staff are random and unannounced
  - Interviews will be conducted and will be private & confidential
  - Payroll records are subject to review
  - All apprenticeship programs will need to be approved by Department of Labor prior to starting
  - The Prime Contractor is responsible for sub-contractor payroll
  - Late payrolls may delay contractor payments, as well as release of retainage

# Contract Requirements

- Insurance requirements for this project are found in Section 5.7 of the GCs
  - Installation Floater required in lieu of Builder's Risk
- SAWWS will ask for insurance prior to Board award to expedite execution of the contract
  - Any deficiencies must be corrected prior to Board award
- Contractor's insurance must be compliant on all SAWWS projects, including this one, prior to executing the contract
- Contractor must maintain insurance coverage during the term of construction of this Project. Failure to maintain compliance may result in the Contractor being asked to stop work at the project site.

# Contract Requirements

- The Contractor shall perform the Work with its own organization on at least 40% of the total original contract price
  - Ensure that this indicated by noting the percentage performed by the Bidder on page I of the Good Faith Effort Plan (and that all work of subcontractors adds up to the remaining percentage no performed by the Prime).
- Liquidated Damages are \$523.00 per day.

# Bid Packet Preparation

- Double-check all mathematical calculations and verify all extensions for each of the line items.
- Ensure Mobilization and Demobilization do NOT exceed **6% of Line Items 1-17 only**.
- In the event of a discrepancy between the written percentage and dollar amount shown for Mobilization and Demobilization bid items, the written percentage will govern. If the percentage written exceeds the allowable maximum stated for mobilization and demobilization, SAWS reserves the right to cap the amount at the percentages shown and adjust the extensions of the bid items accordingly.



# Bid Packet Preparation (cont.)

- **Bid Item Nos. 21 and 22**

- **Deductive and Additive Alternates:** (A36 Steel Carbon Steel (Deductive) & New Clarifier/Access Walkway (Additive))
- SAWS reserves the right to award a contract with or without either of the alternates
- The Total for each alternate should be the full price for the alternate separate from pricing included in the Total Base Bid Price.
  - SAWS will deduct and/or add the alternate to the Total Bid Price if we opt to award with either the Deductive or Additive Alternate
- Mobilization/Demobilization shall be inclusive to each alternate's Total.

# Bid Packet Preparation (cont.)

Bidder shall ensure that the 3 projects submitted on the Statement of Bidder's Experience forms:

- **A-1**
  - Completed by Prime
  - Demonstrates completion of the rehabilitation of a primary or secondary clarifier with a minimum diameter of 60-ft.
  - Completed between 2010-2024
- **A-2**
  - Completed by Prime
  - Demonstrates completion of improvements to a wastewater treatment plant with a minimum capacity of 10-mgd that includes mechanical, electrical, structural, and civil work.
  - Completed within 2015-2023
  - Cannot be the same as A-1 or A-3
- **A-3**
  - Completed by Prime or Sub
  - completion of improvements to a wastewater treatment plant with a minimum capacity of 10-mgd that includes mechanical, electrical, structural, and civil work.
  - Completed within 2015-2023
  - Cannot be the same as A-1 or A-2

# Bid Packet Preparation (cont.)

- Bidder shall
  - Indicate Owner references
    - Provide verifiable with up-to-date contact information for the Owner reference provided
    - Owner is defined as the entity the Bidder performed work for (i.e., City, County, Utility, State, etc.)
  - The design engineer may not serve as a reference for the Bidder.
  - Failure to complete the forms properly or to provide references SAWS can make contact with may result in the bid being found non-responsive.

# Bid Packet Preparation (cont.)

- Utilize the Bid Packet Checklist within the specifications which identifies:
  - Items to be submitted with the Bid
    - List of Bid Items
    - Signed Bid Proposal Signature Page
      - Addendums are acknowledged and Executive Order
    - Signed Proposal Certification
    - Bid Bond
    - Good Faith Effort Plan

## Bid Packet Preparation (cont.)

Items to be submitted upon request by SAWWS from the Apparent Low Bidder within one (1) day of the bid opening, which includes:

- Conflict of Interest Questionnaire
- Proof of Insurability (Letter from Insurer or Sample Certificate of Insurance)
- Company Information Packet
- Statement Regarding Ability to Complete the Project
- W-9
- Schedule of Manufacturers and Suppliers
- Statement of Bidder's Experience forms
- Detailed Baseline Schedule (NTP of 6/10/24)

# Bid Opening Procedures

Bids will be received either:

- **Electronic** bids will be received via the secure SAWWS FTP site.
- **Sealed** bids will be received by Contract Administration, 2800 U.S. Hwy 281 North, Tower II, Customer Center Building, via a black drop box located on the left wall when walking through the first set of double glass doors of the main Tower II entry on the north side of the building.
  - If bids will be delivered in person, Bidders should allow sufficient travel time.
- Late bids will **not** be accepted and will be returned and not opened.
- Bids received will be read aloud publicly via Web Ex.

# Solicitation Schedule

<b>MILESTONE</b>	<b>DATE / TIME</b>
<b>Questions Due</b>	April 19, 2024 at 5:00 PM (CDT)
<b>Answers Posted</b>	April 25, 2024 at 5:00 PM (CDT)
<b>FTP Request Deadline</b>	May 2, 2024 at 2:00 PM (CDT)
<b>Bids Due</b>	May 3, 2024 at 2:00 PM (CDT)
<b>Apparent Low Bidder Notified</b>	May 2024
<b>Board Award</b>	June 4, 2024
<b>Anticipated NTP Date</b>	June 10, 2024

# Restriction on Communication

- Please be advised that Bidders are prohibited from communicating with any other SAWWS staff, the Consultant, the Developer, or City of San Antonio officials regarding this IFB up until the contract is awarded as outlined in the Instructions to Bidders.



# Project Location

- This project includes the rehabilitation of Primary Clarifiers Nos. 1 and 2 at the Leon Creek WRC.

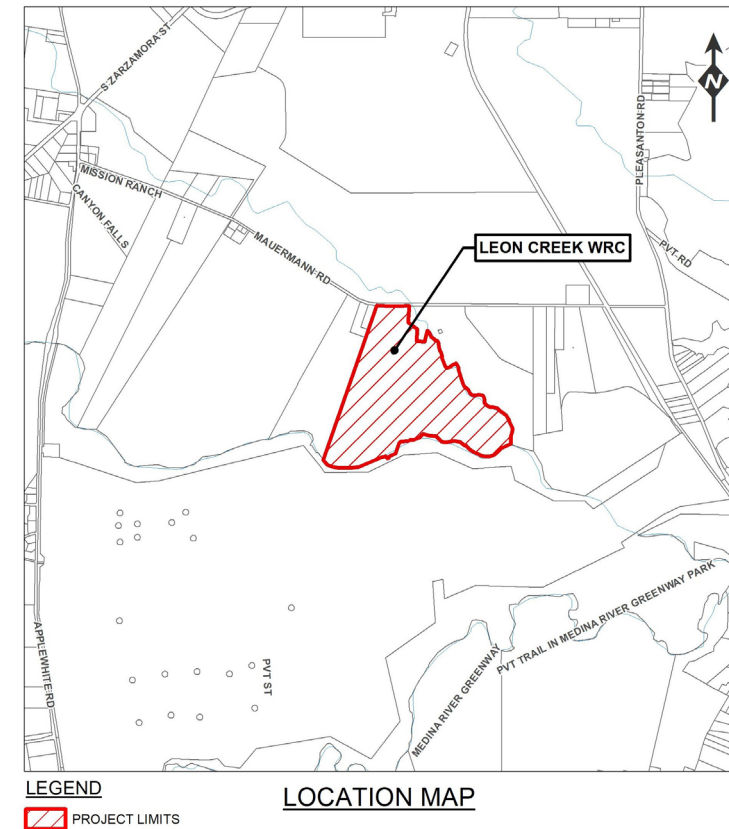
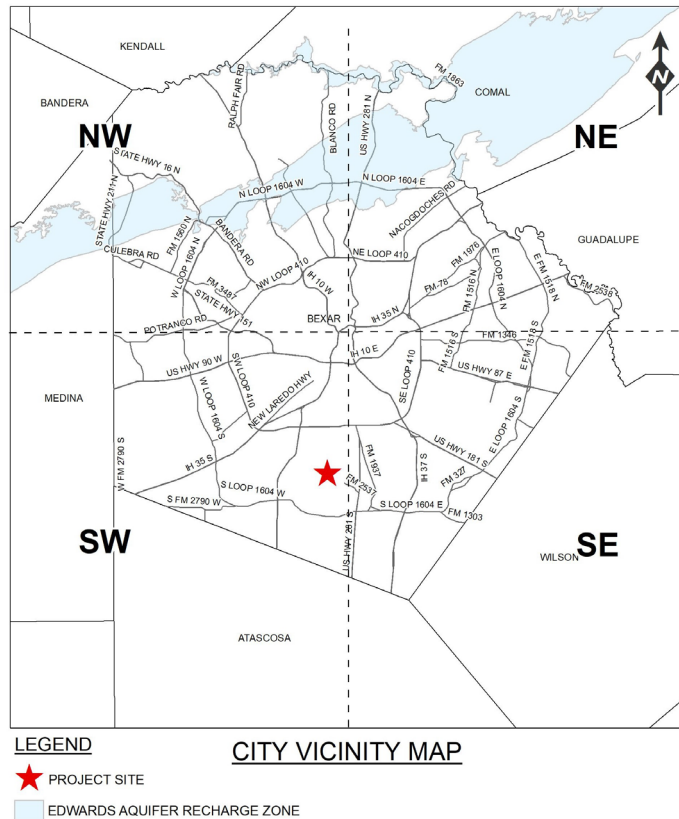

# Project Overview

- Rehabilitation of Primary Clarifier Nos. 1 and 2 (125-ft Diameter).
  - Remove, dispose, and replace primary clarifier mechanical components:
    - Center Pier and Influent Column, Feedwell, Center Drive unit assembly and platform, Center Torque Cage, Rake Arms, Control Panel, Scum Box, V-Notch Weir and Scum Baffle Plate
    - Existing Walkway Bridge to be reuse (Add Alt Option to Replace).
  - Remove and replace electrical system and new lighting.
  - Cementitious and Epoxy Coating Structural Repairs.
  - Other Miscellaneous Structural Repairs.

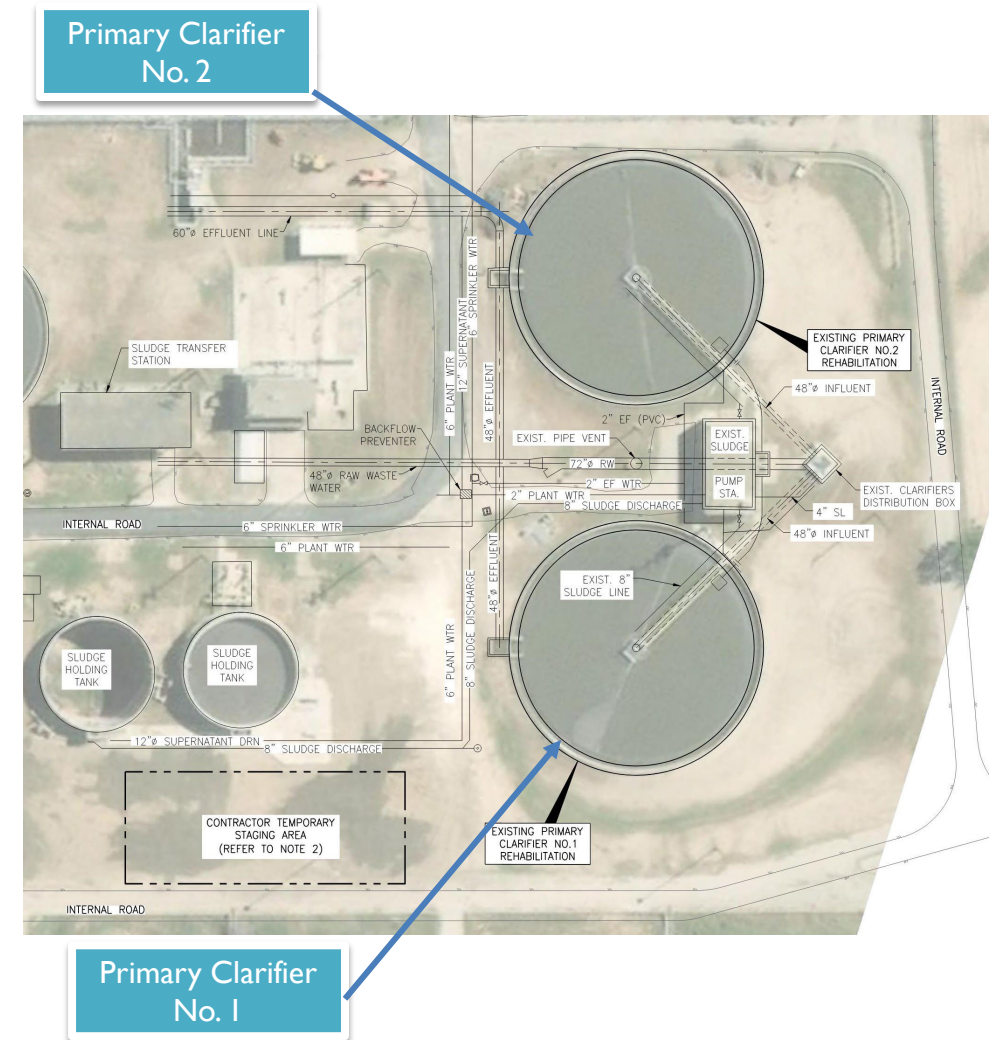

# Project Overview

- Demolition Plan and Section Photographs

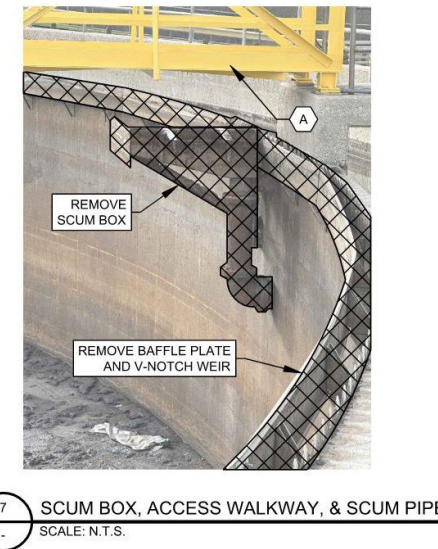
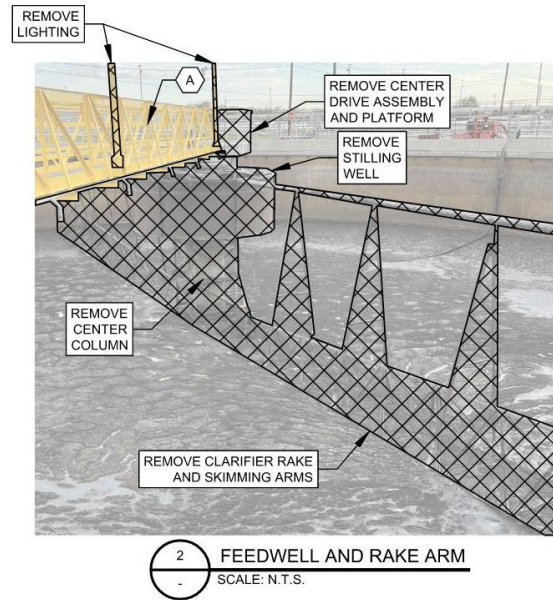
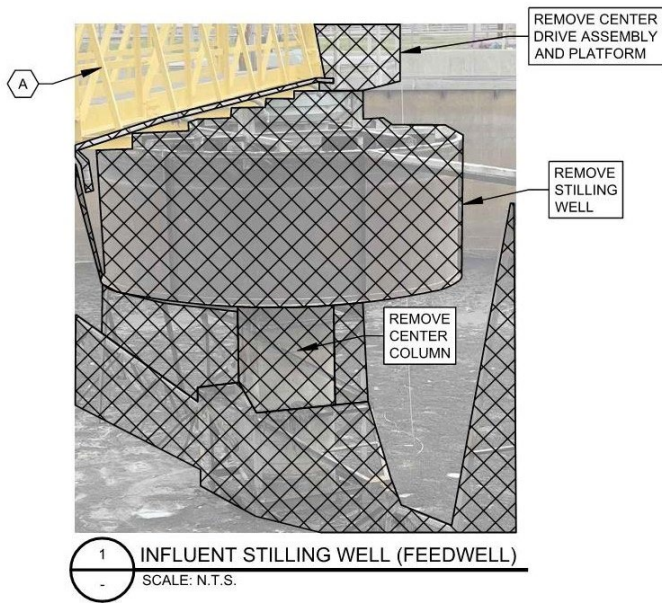

# Project Overview

- Primary Clarifier No. 1 and 2 Plan and Section

Reuse Existing Concrete Basin

Remove and Replace all Mechanical and Electrical Components

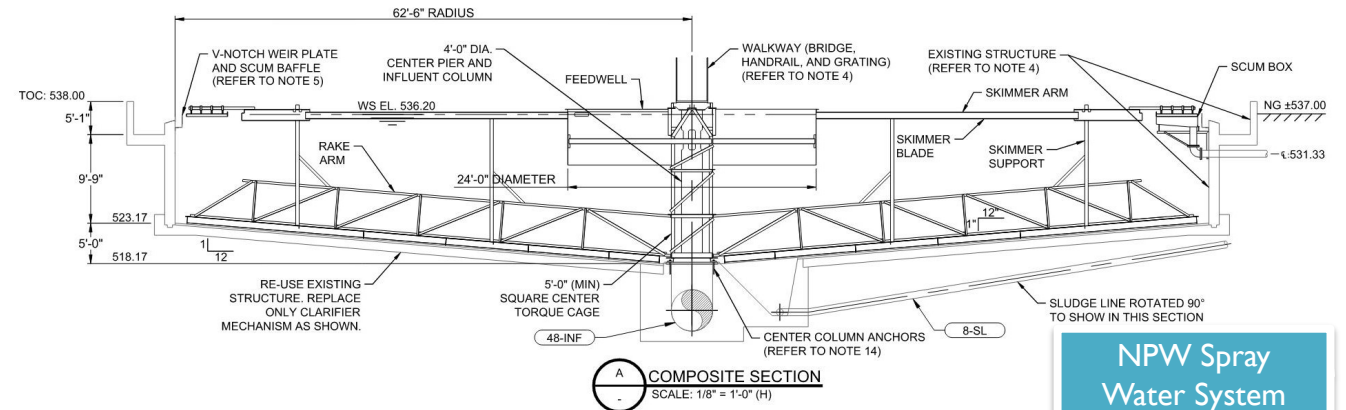
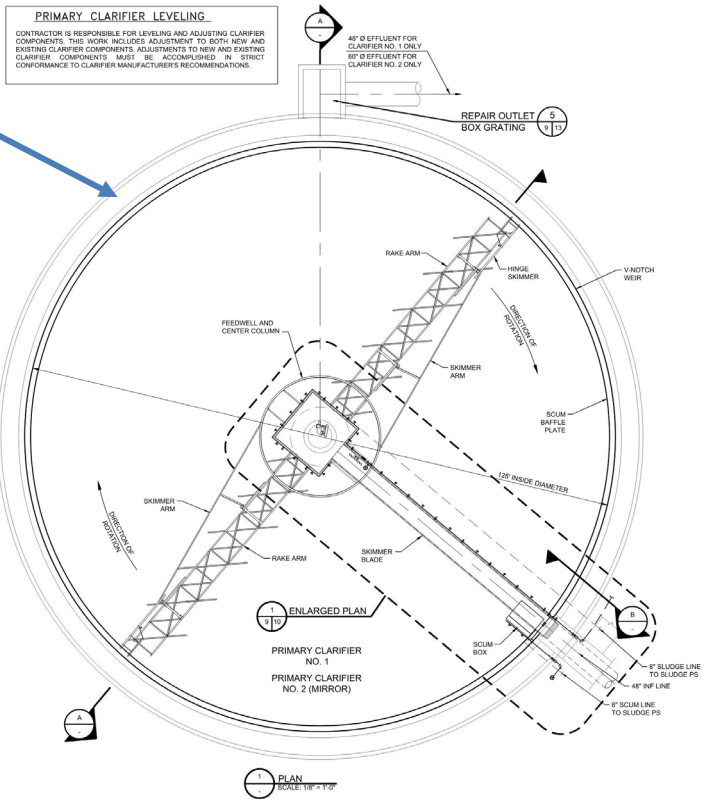

NPW Spray Water System

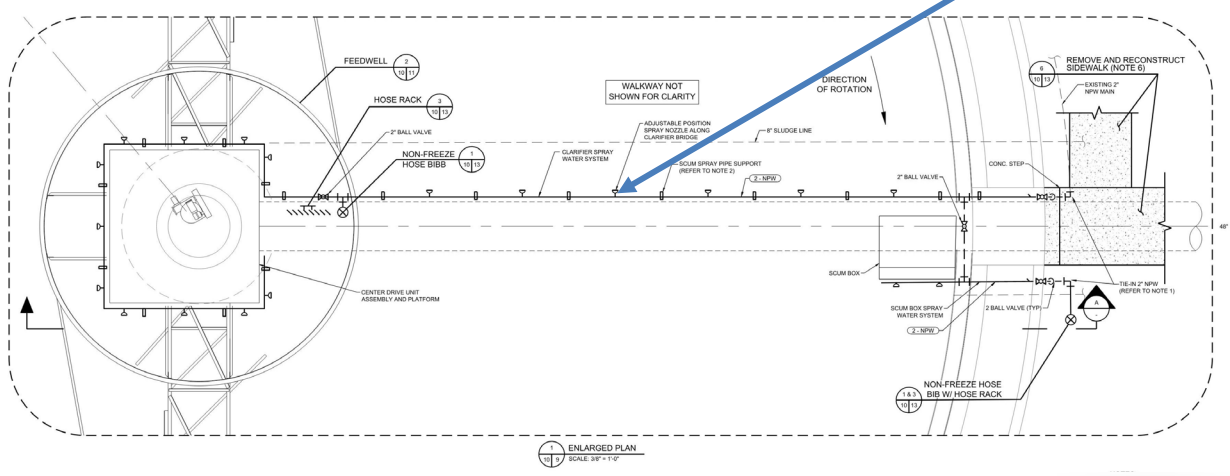

# Project Overview

- Unique Project Features

Field Verify Existing Bolt Pattern as required for new Center Column

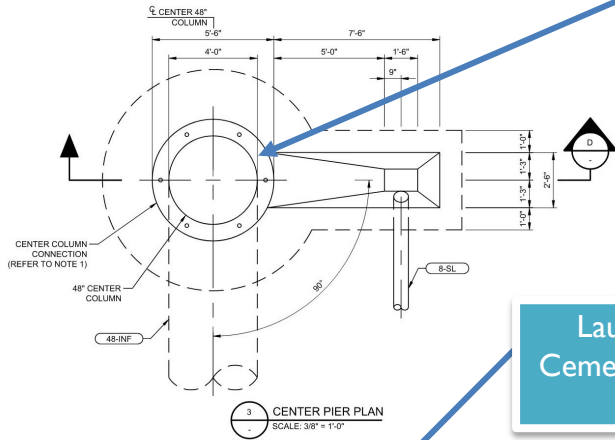

Launder Floor: Cementitious Repair Only

Launder Walls: Cementitious & Epoxy Coating

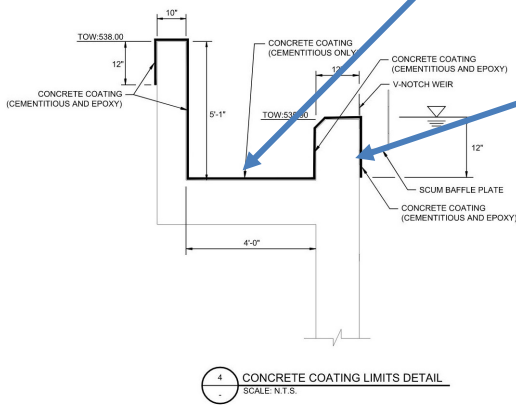

Outlet Box Grating Improvements: Add new support beam

Outlet Box Walls: Cementitious & Epoxy Coating

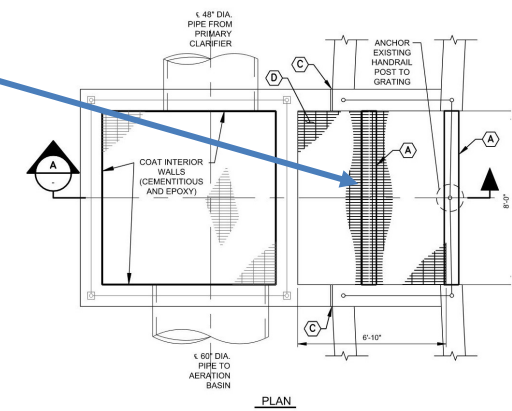

- KEY NOTES:
- (A) NEW GRATING SUPPORT CHANNEL BEAM REFER TO DETAIL 7. SET BEAM SUPPORT AT INTERPHASE BETWEEN THE TWO ALUMINUM GRATING PANELS.
  - (B) ANNULAR SPACE AT ANCHOR POST IN CONCRETE SHALL BE FILLED IN WITH PREMIXED, NON SHRINK, NON METALLIC GROUT, EROSION-RESISTANT.
  - (C) REMOVE ALL GROUT AND CLEAN OUT THE EXPANSION JOIN. INSTALL A BACHER ROD AND TOP WITH AN ELASTOMER SEALANT.
  - (D) REMOVE AND REPLACE ALUMINUM GRATING. PROVIDE PANELS TO FIT OVER OPENING AND USE GRATING FASTENER



# Project Overview

- Unique Project Features



9  
REMAINING SLUDGE AT  
BOTTOM OF CLARIFIER  
SCALE: N.T.S.



10  
REMAINING SLUDGE AT  
BOTTOM OF CLARIFIER  
SCALE: N.T.S.

- No more than 1 Clarifier will be allowed to be taken out of service at any one time.
- SAWS will drain Primary Clarifier No. 1 and 2.
- Any remaining sludge/grit/debris will be removed and disposed of by the Contractor. Bid Line item is provided in the Bid Proposal (Line Item 15).
- Sludge/grit/debris may be disposed of at the on-site sludge drying beds.

# Additive & Deductive Alternates

- Clarifier Materials of Construction
  - Base Bid (304 Stainless Steel)
  - **Deductive Alternative** (Painted A36 Carbon Steel)

- Clarifier Walkway Bridge
  - Base Bid (Rehabilitate)
    - Repair, Sandblast, and Paint Clarifier No. 1 Walkway Bridge
    - Repair Clarifier No. 2 Walkway Bridge
  - **Additive Alternative** (Remove and Replace)
    - Remove and Replace Clarifier No. 1 and 2 Walkway Bridge

ITEM	MATERIAL OF CONSTRUCTION	
	BASE BID	DEDUCTIVE ALTERNATIVE
CENTER PIER AND INFLUENT COLUMN	304 STAINLESS STEEL	PAINTED A36 STEEL, CARBON STEEL
INFLUENT STILLING WELL (FEEDWELL)	304 STAINLESS STEEL	PAINTED A36 STEEL, CARBON STEEL
CENTER DRIVE UNIT ASEMBLY	CAST IRON, ASTM A 48	CAST IRON, ASTM A 48
CENTER TORQUE CAGE	304 STAINLESS STEEL	PAINTED A36 STEEL, CARBON STEEL
RAKE ARM	304 STAINLESS STEEL	PAINTED A36 STEEL, CARBON STEEL
SKIMMING ARM	304 STAINLESS STEEL	PAINTED A36 STEEL, CARBON STEEL
SCUM BOX	304 STAINLESS STEEL	PAINTED A36 STEEL, CARBON STEEL
WEIR AND SCUM BAFFLE	FRP	FRP
ISOLATION BETWEEN DISSIMILAR MATERIALS IS REQUIRED		
ALL A36 STEEL, CARBON STEEL SHALL BE MINIMUM 1/4-INCH THICKNESS (NOTE 13)		
ALL ANCHOR BOLTS AND HARDWARE SHALL BE TYPE 316 SST		

# Allowance

- Allowance items may not be required and are to be used after approval by owner.
- Owner written approval is required for payment of all allowance items.
- Allowance is provided to repair clarifier 2-inch grout floor surface if necessary. Grout floor will be inspected after clarifier is drained and clean.



# Special Conditions

**SC5. Leon Creek WRC SAWS Facilities:** The Leon Creek WRC Site is an existing SAWS Treatment Facility. The Contractor shall provide site access to SAWS as needed to operate and maintain facilities in proximity to proposed improvements.

**SC6. Safety:** Following are the safety conditions for the Contractor to comply with:

- The Contractor shall implement safety measures and take precautions to provide a safe work environment. At a minimum, the safety measures and precautions shall be in compliance with SAWS, City, County, State and Federal requirements.
- The Contractor shall have always at least one person with them that have attended SAWS 1-hour Contractor Safety training.
- The Contractor shall submit to SAWS Risk-Safety team a copy of their Safety Plan for review and approval before the work commences.

**SC13. Plant Operations:** The wastewater plant and process shall remain in operation at all times. Bypass piping/pumping may be required.

**SC16. Third Party Surveying:** The Contractor shall utilize a third-party survey firm for improvements at the Leon Creek WRC (Primary Clarifier No. 1 and 2). No separate pay item (NSPI) is included for this work. \*Addendum 1

# Questions

- Identify the project name as **Leon Creek WRC Primary Clarifier Nos. 1 and 2 Rehabilitation Project, Solicitation No. CO-0075 I-LE**
- Submit in writing no later than April 19, 2024 by 5:00 P.M.(CDT) via e-mail to:

**Lindsay Esquivel**

Contract Administration Department

San Antonio Water System

[Lindsay.Esquivel@saws.org](mailto:Lindsay.Esquivel@saws.org)

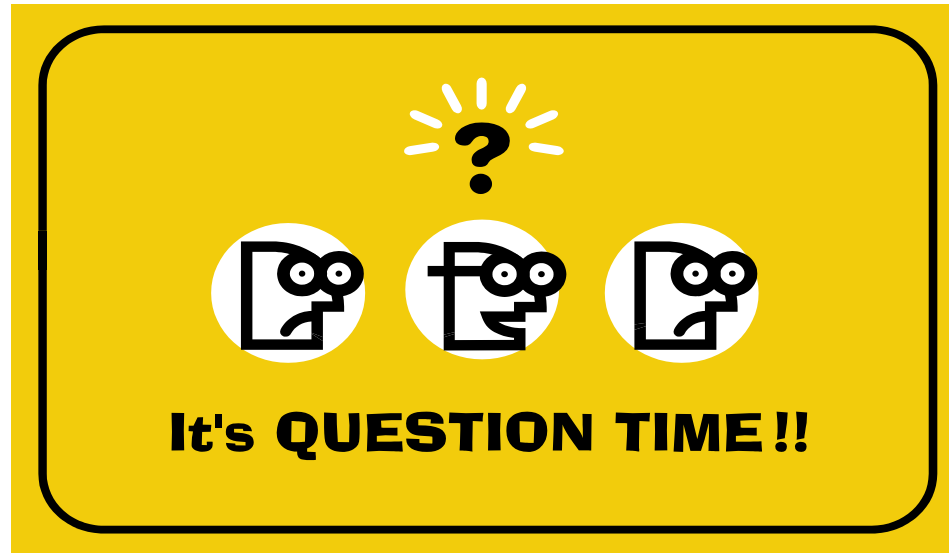

# LEON CREEK WRC PRIMARY CLARIFIER Nos. 1 AND 2 REHABILITATION PROJECT

## Solicitation No. CO-00751-LE

Non-Mandatory Pre-Bid Meeting

April 15, 2024

Lindsay Esquivel

Contract Administrator

Marisol V. Robles

SBOP Manager

Eric Eckols, P.E.

Project Engineer

Javier Garcia, P.E.

Design Consultant

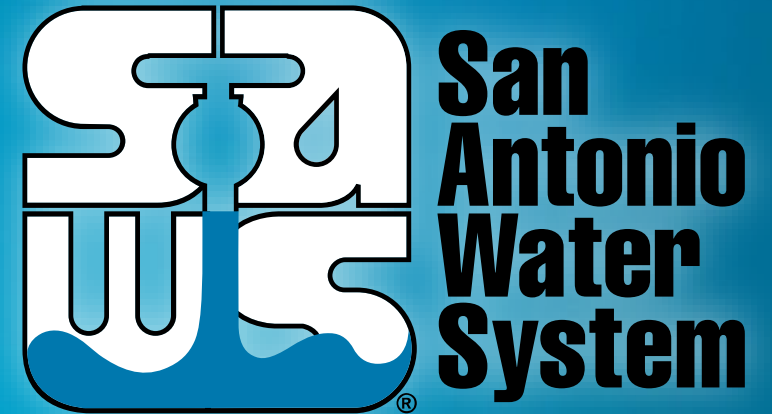

MAKING SAN ANTONIO  
**WATERFUL**

